

Improving Indian Beehives and Beekeeping



Jonathan Abbott
PI: Prof. Alex Slocum

Copyright 2015

TATA CENTER
TECHNOLOGY + DESIGN

CFD of Beehives and Color (Karnataka, India)

Problem

India is hot and hives are often painted dark colors that absorb more sunlight. This makes the bees have to work harder to cool the hive using water.

Modeling

CFD showed the heat transfer coefficient was greatest on the corners and edges.

Findings

Beekeepers can paint just the edges as heat on edges is quickly wicked away.

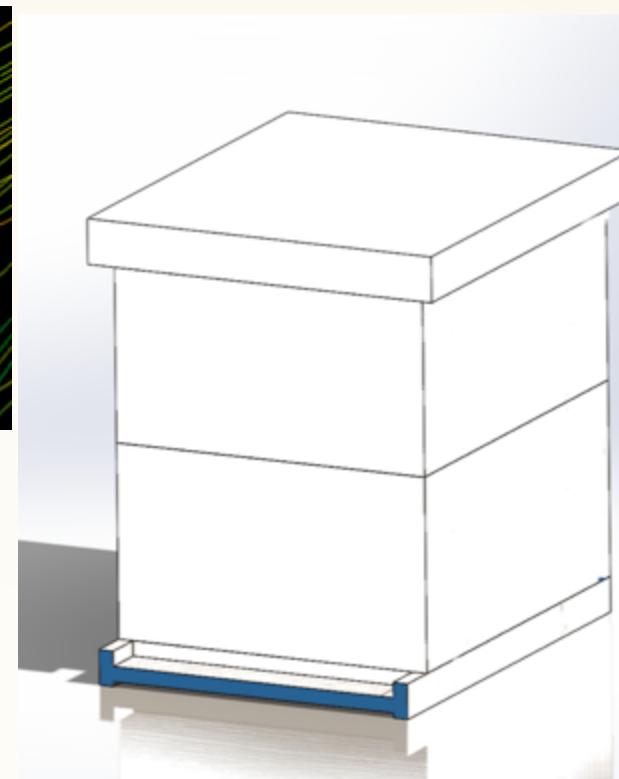
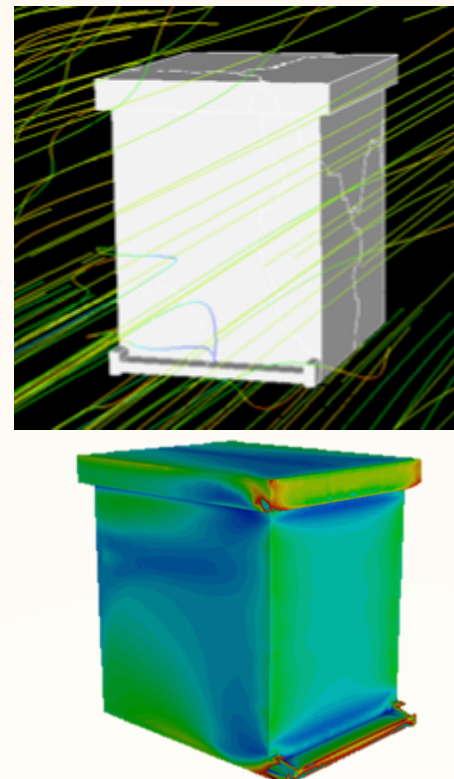

Optimizing the Entrance (US + All India)

Problem

There are many styles and sizes of entrances. What is best way to improve:

1. Ventilation
2. Defendability
3. Traffic Flow

Modeling and Testing

CFD models and lots of tests are helping to distinguish best practices.

Findings

Many insights, including decoupling techniques.

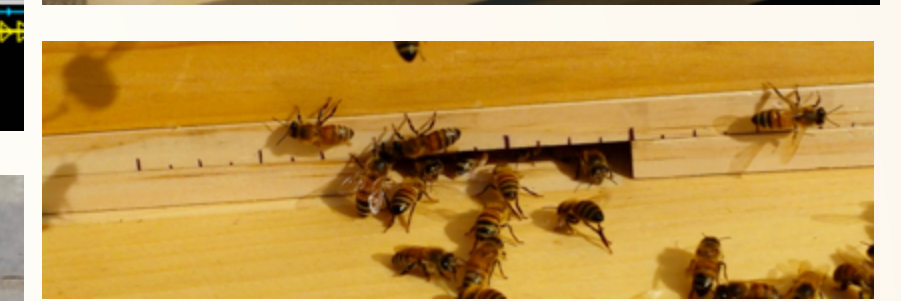
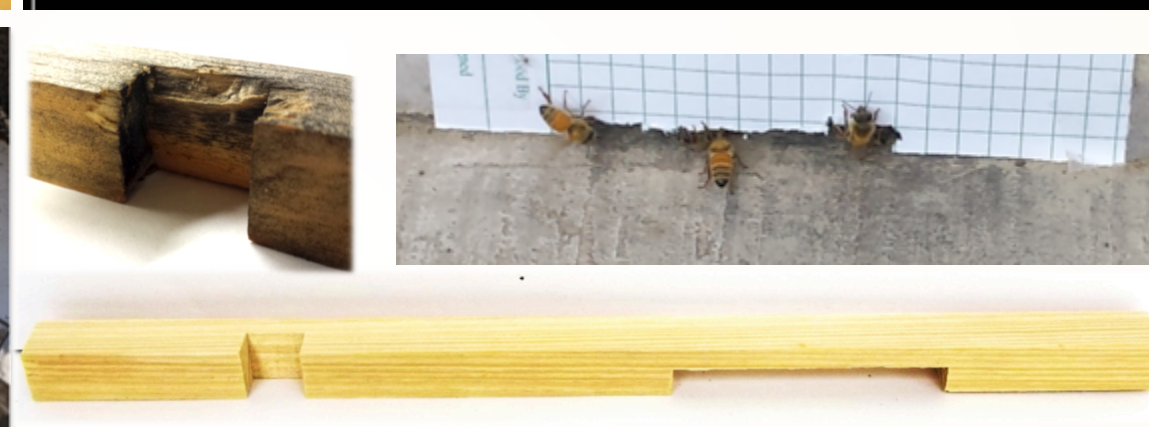
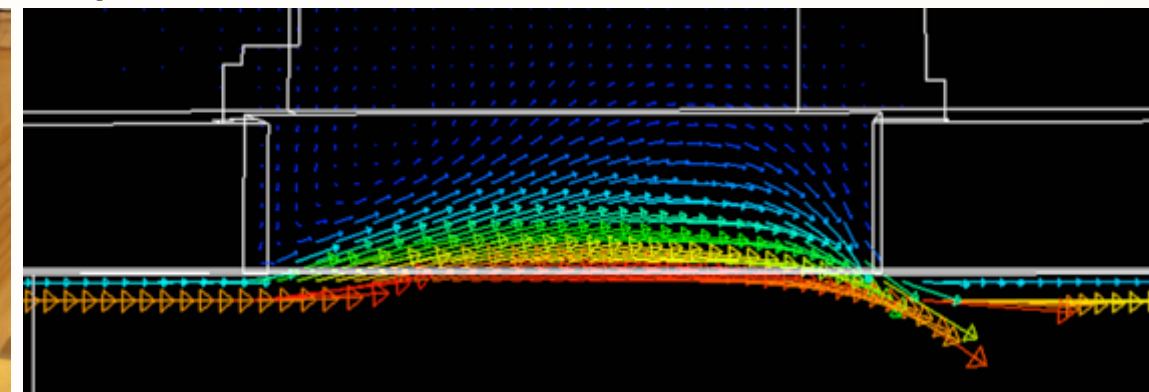

Quality Control of Hives (Uttar Pradesh + All India)

Problem

Indian hive manufacturing has low quality control and hive standardization is poor.

Visiting Manufacturers

Visits to manufacturers help them to improve the quality of their hives while reducing costs and increasing output.

Improving Standards

I am developing hive manufacturing and quality guides for Indian beekeepers as well as making suggestions for the Indian standard.



Roof Design (Haryana + All India)

Problem

Sometimes hives get placed in the sun during summer. The heat hurts the bees.

Testing

6 weeks of testing with radiation barrier roof.

Findings

Designed new cheap roof. Also found Indians use of iron not aluminum potentially absorbs 40% more sunlight. Paint it white!

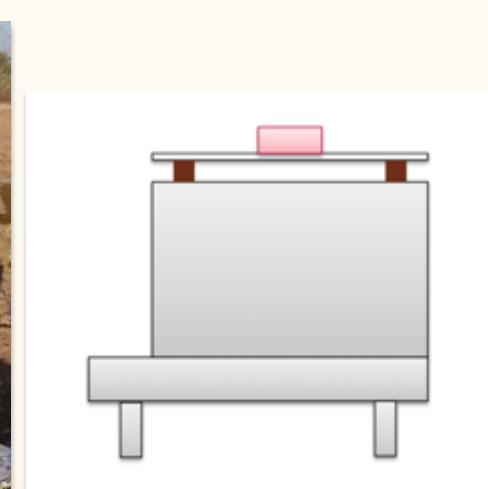

Hive Management (All India)

Problem

The biggest problem for Indian beekeepers is poor hive management.

Design

After a number of iterations, I developed a simple, cheap-to-make hive management tool.

Findings

Beekeepers are willing to pay 10 INR each. Manufacturers are excited to make this.

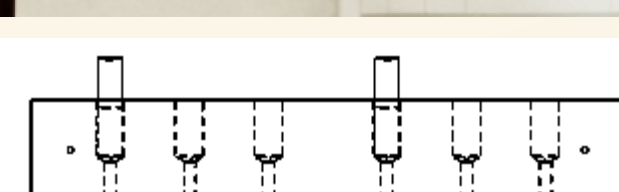
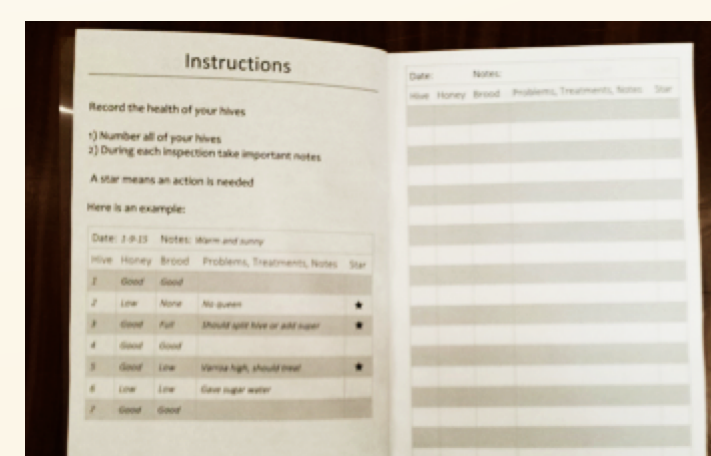

Green is good
Yellow is ok/unknown (check later)
Red is bad (action needed)